

ADVANCE PLATFORM LOADER

Features

- ❖ Touch screen panel enables swift adjustment for various types of magazines in operation
- ❖ Multi-magazine type manual loading (quantity depends on dimension of magazine)
- ❖ Stores up to 10 different types of magazine dimensions
- ❖ Suitable for 'high-mix', 'low-volume' operations
- ❖ Servo motor drive for precise indexing
- ❖ Pneumatic pusher's pressure regulated
- ❖ SMEMA compatible

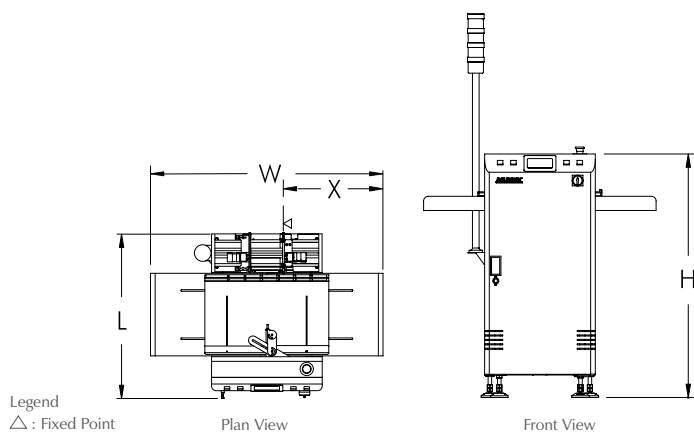

SPECIFICATIONS

Description	This unit is used for loading of substrates, leadframes or carriers.		
Magazine		Min (mm)	Max (mm)
	Width	25	254
	Length	100	330
	Height	less than 330mm	
Indexing Pitch	6 mm pitch or specify		
Power Source	100, 230VAC 1Ph		
Power Consumption	850VA max		
Air Pressure	4 - 6 bar		
Air Consumption	1.1 ltr/min max		

Size	Model No.	Machine Dimension (mm) L x W x H	Fixed Point to Front Dimension (X)	Weight (Approximately)
M	NTM4410LM	760 x 1050 x 1150	450 mm	165 kg